



CRB300



CRT290

CRB300

CONSTRUCTION CONDUCTOR CAR FOR BUNDLED CONDUCTOR LINES

according to EN50374:2004

CRT290

CONSTRUCTION CONDUCTOR CAR FOR BUNDLED CONDUCTOR LINES

according to EN50374:2004

CONFIGURATION

This construction conductor car is made of light aluminium alloy for 2 bundled conductors - 2 rigid axles - conductive wheels - one lineman.

CHARACTERISTIC

CAPACITY	100 kg
WEIGHT	30 kg

CONFIGURATION

This construction conductor car is made of light aluminium alloy for 2-3 bundled conductors - independent wheels - conductive wheels - one lineman.

CHARACTERISTIC

CAPACITY	120 kg
WEIGHT	35 kg

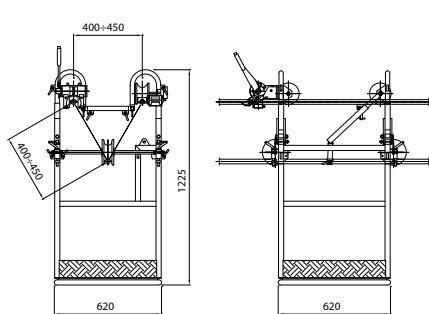

CRT290

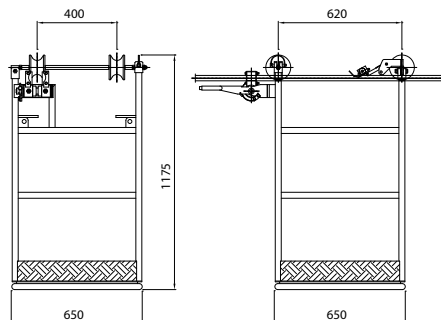

CRB300