

55A

Automotive Equipment

 **Smontagomme Camion Elettroidraulico**

 **Electrohydraulic Truck tyre changer**



Essenziale, efficace e concreto come solo l'esperienza Teco può offrire.
Grandi performances per ogni esigenza lavorativa.

Essential, effective and concrete as only the Teco experience can offer.
Great performances for every business need.

NEW



Smontagomme elettroidraulico SOLIDO, COMPATTO E AFFIDABILE!
Electrohydraulic tyre changer: STRONG, COMPACT AND RELIABLE!

- (IT) **SMONTAGOMME ELETTRIDRAULICO** per pneumatici di autocarri, autobus, trattori e veicoli di movimentazione terra, con cerchi a canale o ad anello elastico e per pneumatici con o senza camera d'aria.
- (EN) **ELECTROHYDRAULIC TYRE CHANGER** for trucks, buses, tractors and earth moving equipment with groove or elastic ring type rim wheels and with tubeless or inner tube type tyres.



Nuova funzione, Standby automatico! New function, Automatic standby!

L'utilizzo della funzione **energy management** permette un notevole risparmio energetico nella fasi di inutilizzo della macchina. *The **energy management** function allows for a significant energy saving when the machine is not being used.*



(IT)

MANIPOLATORE

Manipolatore intuitivo con comandi ergonomici. **Novità: il pulsante per l'arresto immediato di tutti i movimenti e il kit radio (a richiesta)**

CENTRALINA

Nuova centrale elettro-idraulica per un'impiantistica sempre performante e all'avanguardia.

(EN)

CONTROL MODULE

Intuitive control module with ergonomic controls. **New: the button for immediate stop of all movements and the radio kit (on request)**

CONTROL UNIT

New electro-hydraulic control unit for always performing and cutting-edge systems.



(IT) **AUTOCENTRANTE** Nuovo mandrino autocentrante con rotazione oraria ed antioraria a due velocità

(EN) **TURNTABLE** New turntable with two-speed rotation both clockwise and anticlockwise.



1 Griffe in acciaio ad alta resistenza, con inserti in plastica di differenti spessori per poter bloccare in sicurezza ogni tipo di cerchio senza danneggiarlo. **2** Prolunghe per bloccare cerchi fino a 56" (a richiesta). **3** Griffe speciali per cerchi in lega con inserti in plastica (a richiesta).

1 Special clamps in high strength steel, with plastic inserts in different thicknesses for clamping all wheel types safely without the risk of damage. **2** Extensions for clamping wheels up to 56" (optional). **3** Special clamps with plastic insert for alloy rims (optional).

NEW



(IT) **GRUPPO UTENSILI** Carrello utensili con doppia postazione di lavoro per azioni veloci e precise. **Nuovo è il braccio utensili.** Il carrello è azionato da un cilindro idraulico.

(EN) **TOOL UNIT** Tool carriage with double workstation for fast and precise actions. The **tool arm is new.** The carriage is operated by a hydraulic cylinder.

Peso ruota fino a 1000 kg
Wheel weight 1,000 kg



1000 kg

DIMENSIONI DI INGOMBRO - OVERALL DIMENSIONS

PESO MACCHINA	782 kg
MACHINE WEIGHT	

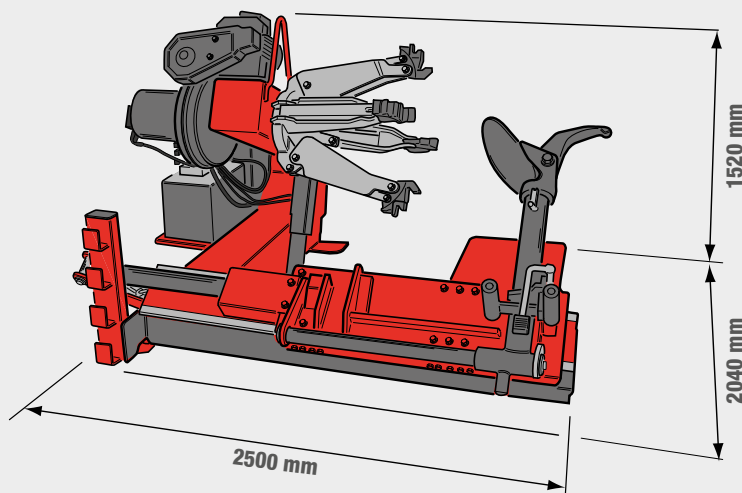

Smontagomme Camion Elettroidraulico Electrohydraulic Truck Tyre Changer

DATI TECNICI - TECHNICAL DATA

LARGHEZZA MAX. RUOTA	MAXIMUM WHEEL WIDTH	1065 mm
DIAMETRO MAX. RUOTA	MAXIMUM WHEEL DIAMETER	2300 mm
CAPACITÀ DI BLOCCAGGIO	CHUCKING DEVICE CAPACITY	14" ÷ 46" (56" con prolunghe - 56» by using extensions)
Ø MINIMO FORO CENTRALE RUOTA	WHEEL CENTRAL HOLE MINIMUM Ø	100 mm
MOTORE CENTRALINA IDRAULICA	HYDRAULIC POWER UNIT MOTOR	1,5 kW
MOTORIDUTTORE A DUE VELOCITÀ	2-SPEED GEAR MOTOR	1,3 ÷ 1,8 kW
CAPACITÀ CILINDRO SOLLEVAMENTO RUOTA	WHEEL LIFTER CYLINDER CAPACITY	1600 kg
PESO MASSIMO RUOTA	MAX. WHEEL WEIGHT	1000 kg
COPPIA MAX. FORNITA	MAX. TORQUE DELIVERY	4000 Nm
FORZA STALLONATORE	BEAD BREAKER FORCE	27000 N
VOLTAGGIO	VOLTAGE	230/400V - 3Ph - 50/60Hz
PESO MACCHINA	MACHINE WEIGHT	782 kg

ACCESSORI DI SERIE - STANDARD ACCESSORIES



ACCESSORI CONSIGLIATI

1_PCL - Adattatore bloccaggio cerchi in lega

2_801227195 PAR
Pinza per cerchi in lega

3_0-12100701 PBP120
Premitalлоне pneumatico

4_801262417
Morsetto in plastica per cerchi in alluminio

5_8-12120025
Kit radio POWER-SGP

ACCESSORI CONSIGLIATI - RECOMMENDED ACCESSORIES

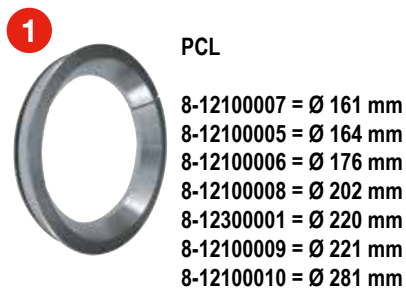

RECOMMENMDE ACCESSORIES

1_PCL -Clamping alloy rim adapter

2_801227195 PAR
Alloy rim clamp

3_0-12100701 PBP120
Pneumatic bead pressing tool

4_801262417
Plastic clips for aluminium rims

5_8-12120025
Radio POWER-SGP kit

*Per altri accessori consultare l'apposito catalogo - *For other accessories, please refer to the relevant catalogue

Fotografie, caratteristiche ed i dati tecnici non sono vincolanti, possono subire modifiche senza preavviso - Photographs, features and technical data are not binding, they are subject to change without notice